

PRODUCT DESCRIPTION

Circular Column Formwork is engineered to form concrete column. It is very easy to handle, and extremely light. The product is very strong and extremely versatile and includes an oil lined inner for easy stripping. Circular column formwork achieves a smooth Class 1 finish.

BENEFITS

- Suitable for round column construction
- Very easy to handle and fast to use
- Low cost
- Water resistant plastic outer covering
- Oil lined inner for easy stripping
- Optional plastic insert
- Biodegradable
- Light weight
- Can be manufactured to your desired requirements (rigid for piling and flexible for various applications)
- It is environmentally friendly made up of non-hazardous materials which all can be recycled
- It is weatherproof and can also be designed for underwater applications not affecting its strength
- It can be offered in a range of desired finishes including spiral lined and textured
- Standard Diameters are shown on next page (for custom sizes please consult on of our technical staff members who will be able to design and assist to your specifications)



AREAS OF APPLICATION

- All round column construction

FORMING DETAILS (Not to scale)

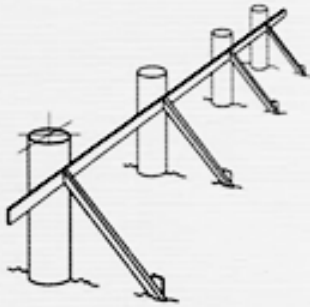
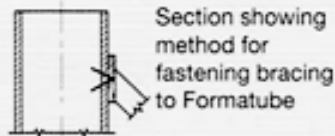
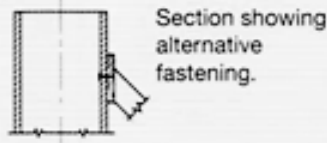

Fig 1: Columns on a line
Bracing for relatively short columns – where height to diameter does not exceed 12 to 1.



Section showing method for fastening bracing to Formatube



Section showing alternative fastening.

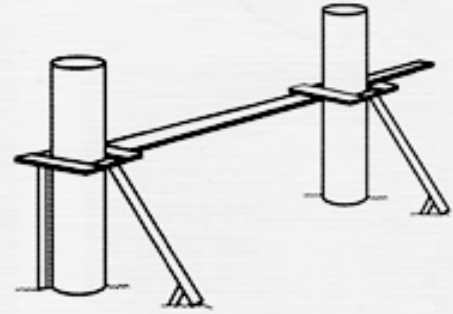

Fig 2: Columns on a line
Bracing for relatively short columns.



Fig 3: Tall Column Bracing
Bracing for tall columns where already erected building framing or scaffold is available for support.

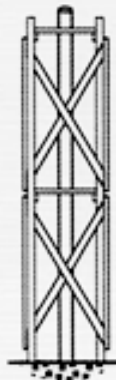

Fig 4: Tall Column Bracing
Alternative bracing for tall columns where support from building framing or scaffold is not possible.

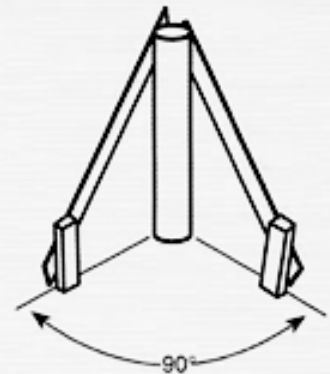

Fig 5: Short Column Bracing
Bracing for short single columns.

DANTERR COLUMN DIMENSIONS

Internal Diameter	Extended Diameter	Avg Weight per Metre
260	264	1.00
310	314	1.25
360	364	1.75
410	414	2.00
460	464	2.25
510	514	2.50
560	564	2.75
610	614	3.00
660	664	3.25
710	716	4.25
760	766	4.75
810	816	5.25
860	866	5.75
910	916	6.25
960	966	6.75
1010	1016	7.25
1060	1066	7.75
1110	1116	8.25
1160	1166	8.75
1210	1216	9.25
1260	1266	9.75
1310	1317	10.25
1360	1367	10.75
1410	1417	11.25
1460	1467	11.75
1510	1517	12.25

Note: These specs are based on standard column specs for use up to 5m for details on longer lengths columns can be modified to ensure safe pour heights in compliance with Australian Standards. We manufacture bigger diameters with another system.

HANDLING OF DANTERR COLUMN TUBES

TRANSPORTATION

Danterr columns can optimise maximum space in transportation as they have a flexible tolerance allowing you to load an average of 30% more columns on a truck by squashing them down.

Due to thin wall structure smaller Diameters can also be placed inside larger columns to optimise space.

UNLOADING MANUALLY

Danterr columns can be removed manually by sliding columns off the back of the truck. It is recommended that columns are handled with care as if they are thrown off can create unwanted creases which will affect the finish of the column.

UNLOADING WITH THE AID OF A CRANE

In this situation it is advised that the columns are lifted with slings (we recommend the use of slings as chains can create internal creases which will not affect the strength of the tube but can create unwanted surface marks on the finished concrete.) It is also crucial that slings securely hold the column tubes when lifting.



STORAGE

Danterr columns are water resistant and can be left onsite in a horizontal position, however, it is best to place and fill columns as soon as possible after delivery. Avoid continual movement of columns around sites as this may cause unwarranted damage. Do not over stack columns and ensure that they are held in position by placing timbers on either side of the tubes and stacking them in a pyramid shape. It is recommended to turn columns around if they begin to warp after long periods of storage. Columns stored for any length of time should be protected from the elements or placed under cover. If placed upright please ensure that columns are secure. Due to the light weight of the product, they may be blown over by wind, therefore they should be securely braced and tied. It is not advised to place columns high than 3m in an upright position.

COLUMN INSTALLATION

Columns can be installed in several ways. The two most common are listed below. If you require a setup which is not listed below (example, submerged, angled, etc please contact our technical department).

POUR UP METHOD

Where columns are set up prior to the suspended slab ie stood vertically from the base slab, they are lowered down over the column reinforcement. Consideration should be given to any cogged bars at the top which are wider than the tube diameter as this will prevent placement of the tube. Cogged bars can be turned in and turned back out if approved or top cogs can be placed after the tube is in place, subject to the project engineer's approval. Ensure bar chair spacers are attached to the column reinforcement to avoid scratching or tearing the liner. Alternatively, PVC conduit can be easily attached to the outside of the column reinforcement and removed after the tube is positioned. The tubes are then braced and leveled accordingly with diagonal bracing.

We recommend that a circular collar cut out to the external diameter of the Danterr tube is used and placed no less than 100mm from the top of the tube. This collar can be supported by 3 vertical bearers to create a tripod like support to aid in the stability of keeping the column level. The bearers should not contact the tube. Diagonal bracing can then be attached and the column plumbed vertically. The bottom of the tube is to be braced for lateral movement by fixing four (4) timbers (kickers) equally spaced ie at North, South, East and West points at the bottom of the column so that they are positioned on the outer face of the tube. They should not push into the base of the tube and they should allow the tube to expand to the full diameter when the concrete is poured. Ensure top and bottom of the column have a nail placed into support and tube ensuring no lift or movement once leveled.

POUR DOWN METHOD

Where columns are installed from a suspended deck, the tube is lowered into position from above through the circular penetration in the beam/slab soffit plywood. The top of the column must be nailed to the plywood to ensure the column doesn't move. Please ensure that the cut out is at the correct external diameter to ensure that the column is free to take its shape. The bottom of the column is braced for lateral movement as per the detail in a) above. The bottom of the column must have a nail placed into the base support and tube ensuring no lift or movement once leveled (we recommend two nails on top and bottom opposite each other).

As per a) above, ensure bar chair spacers and or conduit is in place to avoid damage to the liner before lowering tube into position.

COLUMNS FOR PIER AND PILES

When installing, ensure that the column is placed into the pier hold without excessive ground pressure. Columns can be designed to all specified grounds ie sand, water, dirt. It is all crucial that columns are not subject to any piling after the installation of the pier column.

CUTTING COLUMNS

When columns need to be cut they should be cut using a Stanley knife or equivalent. If the column is lined ensure to retape the liner to the column so that no concrete can enter in between the tube and the liner. This is very important. We recommend that all lined columns be ordered and heights specified so that we can cut to size in our factory to ensure the best quality finish.

If any box outs need to be added or plates etc we recommend you call our technical department as any form of penetration to the column could affect the strength of the tube. Instructions on reinforcing the column can be given depending on the specifications.

POURING OF CONCRETE

Before pouring check all columns are braced adequately and internal liners have not been displaced. It is crucial that the concrete is poured into the column by placing the pump hose and vibrator as far down as possible. Pouring from the top of the column is not recommended and can lead to damage of the liner and also the finish of the tube. If the column is not vibrated evenly there is a high chance of honeycombing. Ensure concrete pour rates are not exceeded.

STRIPPING COLUMNS

All supports should be removed and the columns should be clear of any possible interference. A knife can be used to cut a vertical incision from the top to the bottom of the column. Ensure not to cut through to the concrete as this may scratch or damage the surface finish of the concrete.

Alternatively, utilise the option of Danterr Stripping Tape, which will split the column vertically for easy removal of the tube.

Once the outer column shell is cut, peel off the tubes and safely place on the ground. Cut the column shell into manageable pieces for ease of handling and dispose of responsibly into rubbish bins.

CARE RECOMMENDATIONS PRIOR TO USE

PREINSPECTIONS

It is recommendable to check the goods once they have been picked up:

- Cuts/damage to outside of the tube/reinforcing
- Inspection of internal liner
- Check tape at ends of tubes are properly secured

Store tubes correctly

- Out of the weather
- Without deforming
- Secure from wind
- Store in a safety area out of the way of workers

Check dimensions of the tubes

- When cutting is required, contact Danterr to ensure correct tapes and re-taping techniques are employed

Inspection of the tubes prior to installing over reinforced steel

- No damage to inside liner
- No external damage
- Ensure that the tape at ends of tube is secure and effective to avoid concrete egress

SET UP

1. Inspect the steel reinforcing to ensure that no tie wire, stirrups, reo bars, or other material is protruding that may scratch the liner of the form whilst installing
2. Fit PVS conduits on outside of reo bars to ensure safety and quality of form is maintained as per order requirements
3. Tube to maintain outer round shape at all times
 - a) Use round ply template or timber do not allow horizontal movements on base and top of form
 - b) IMPORTANT: no external bracing to be applied to the tubes unless specified and agreed to by a certified Danterr representative

POURING

Prior to commencing the concrete pour, inspect the inner liner and the outer tube for any obvious damage that may either result in poor surface finish, or any other potential risks.

Prior to pouring the concrete, check the Danterr Product Data sheet to ensure whether the pour is unrestricted or should meet a specific pour rate. The maximum unrestricted pour heights vary for each column diameter, and Danterr shall supply the relevant wall thickness to achieve safe filling up to the maximum allowable unrestricted pour heights. Higher columns requiring controlled pour rates shall be poured at the prescribed controlled pour rate up to the maximum allowable controlled pour height. For column heights greater than the maximum allowable controlled pour rate, confirm with Danterr as to whether thicker wall tubes are possible, or multiple pours are required for such column heights.

When pouring the concrete into the Danterr column form, place the concrete pump hose and vibrator within the centre of the steel cage and position both as low as possible towards the base of the tube.

Upon commencement of the concrete pour, withdraw both the hose and vibrator evenly during the pour. Do not move the vibrator up and down excessively as this will increase the incidence of honeycomb on the concrete surface, and may result in vibrator burns on the inner liner/tube.

Do not rest the host on the top of the tube during a pour as this may result in damage to the top of the tube or taped liner interface, and concrete may enter between the tube and the inner plastic liner.

Do not direct the flow of concrete towards the wall of the tube, as the aggregate in the concrete may wear through the inner liner, or damage the inner liner join/seam and also result in concrete entering between the liner and the tube.

The reference to the suitability of the Danterr for unrestricted concrete pour rates relates to the tubes ability to ensure adequate strength/burst resistance.

Faster/unrestricted pour rates may however result in a poorer surface finish of the concrete which is purely a function of the concrete properties and the pouring method employed. (Danterr cannot be held responsible for poor surface finishes as a result of difference concrete mixes or pouring methods).

Particular attention should be paid to high columns with modified or Greenstar concretes. Any concrete mix which has a significantly extended initial set time (say greater than 2 hours) should be identified and the concrete specific properties advised to Danterr to check the suitability of the individual pour heights required.

Other than ensuring adequate care is taken in storing and placing a column forming system, the greatest variable on achieving a suitable surface finish on the column form relates to the type of concrete used, and the method of placing/pouring and vibrating the concrete.

- Inspect the columns for internal damage to the liner, or delamination of the tape at the ends of the column form.
- The vibrator should be placed at the centre bottom of the column prior to the concrete being poured.
- The concrete should be placed using a suitable hose/rubber capable of reaching the base of the tube/column form.
- As the concrete is poured, the rubber and the vibrator shall be withdrawn progressively in an even and upward motion, avoiding excessive downward motions of the vibrator.
- References that Danterr can be poured at unrestricted pour rate relates to the tubes strength and ability to resist rupturing (check the maximum g' d' d' UFW

NOTE: unrestricted/fast pours may result in reduced quality of surface finish of the column. For any further information or clarification, please do not hesitate to contact the Danterr customer support team.

CIRCULAR COLUMN FORMWORK

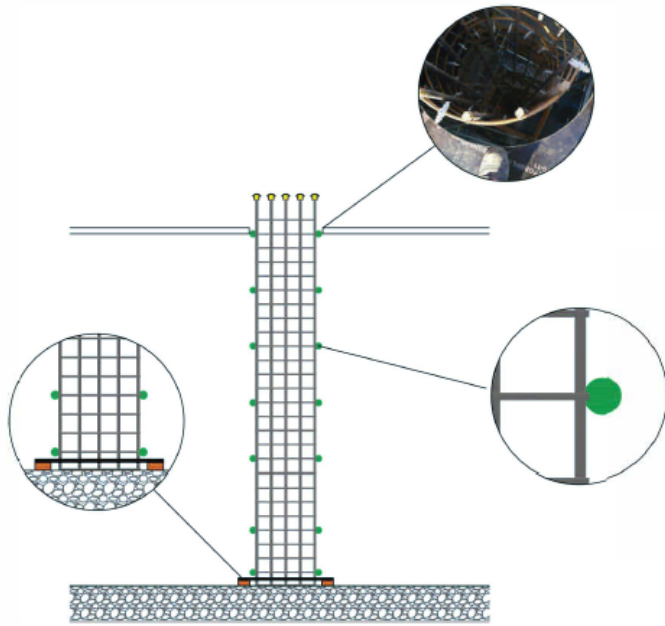

STEP 1
Ensure bar chair spacers are attached to the column reinforcement to avoid scratching or tearing the liner.
Use round ply template or timber to not allow horizontal movements on base and top of form.
IMPORTANT: no external bracing to be applied to the tubes unless specified and agreed to by a certified Consystex representative.

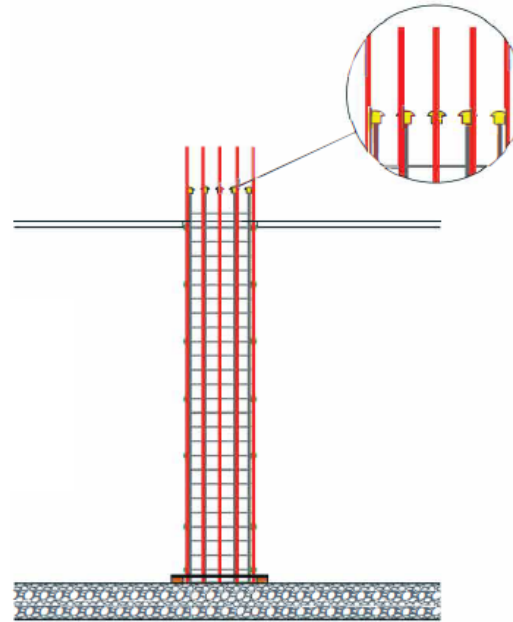

STEP 2
PVC conduit can be attached to the outside of the column reinforcement and removed after the tube is positioned.

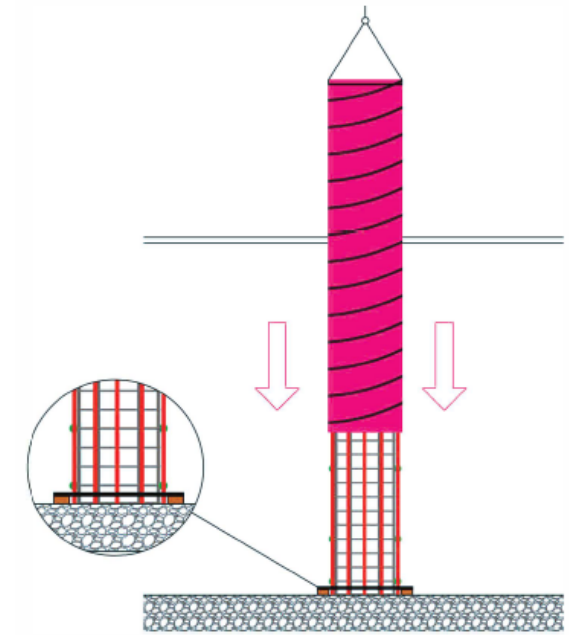
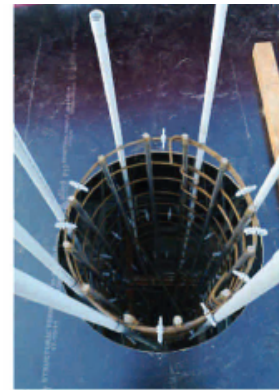

STEP 3

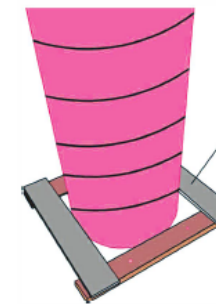

You can use timber or round ply template to not allow horizontal movements on base

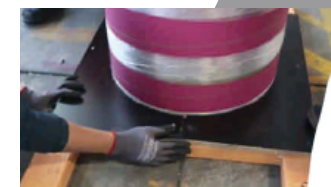
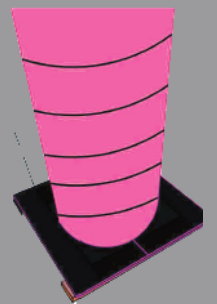

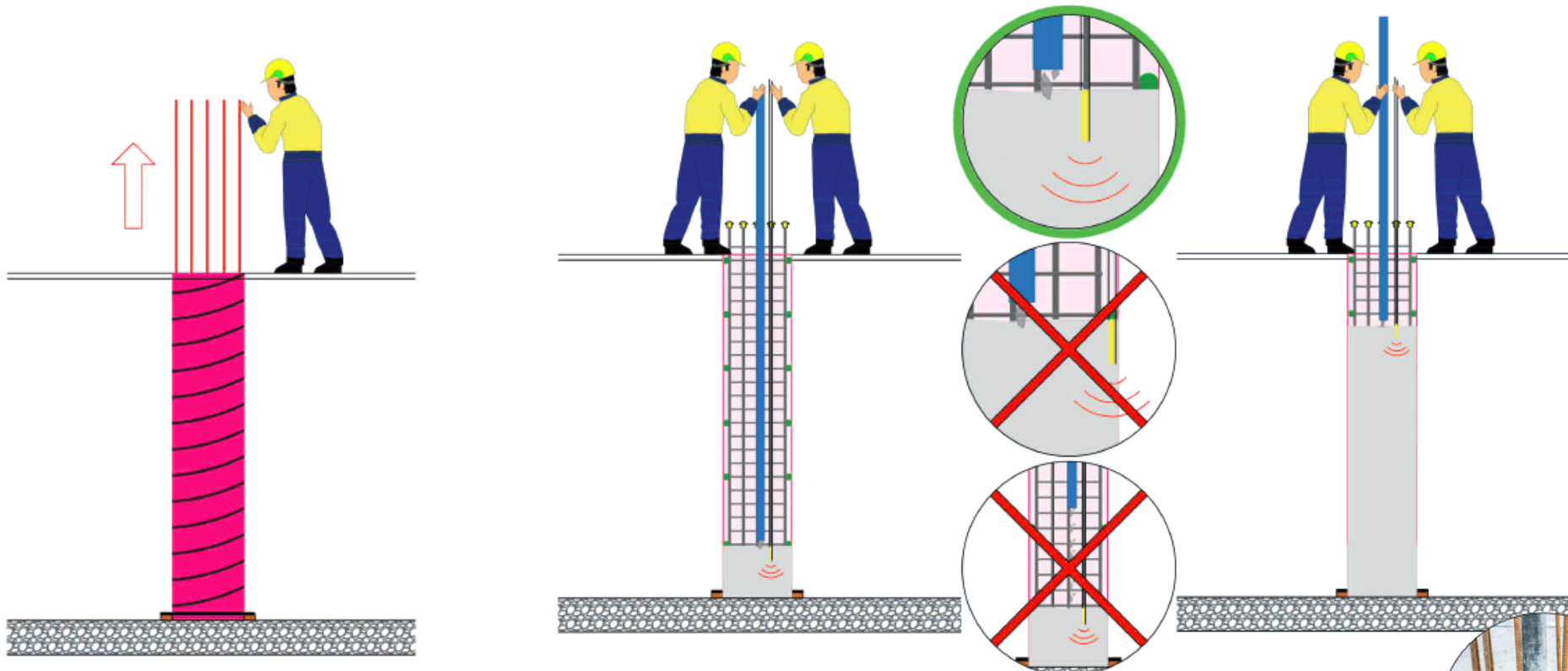

PVC conduit needs to be removed after the tube is positioned

Before pouring check all columns are braced adequately and internal liners have not been displaced. It is crucial that the concrete is poured into the column by placing the pump hose and vibrator as far down as possible. Pouring from the top of the column is not recommended and can lead to damage of the liner and also to the finish of the tube.

Vibrator should at no time contact the liner. Extended contact with the liner can cause damage and leakage. Ensure concrete pour rates are not exceeded



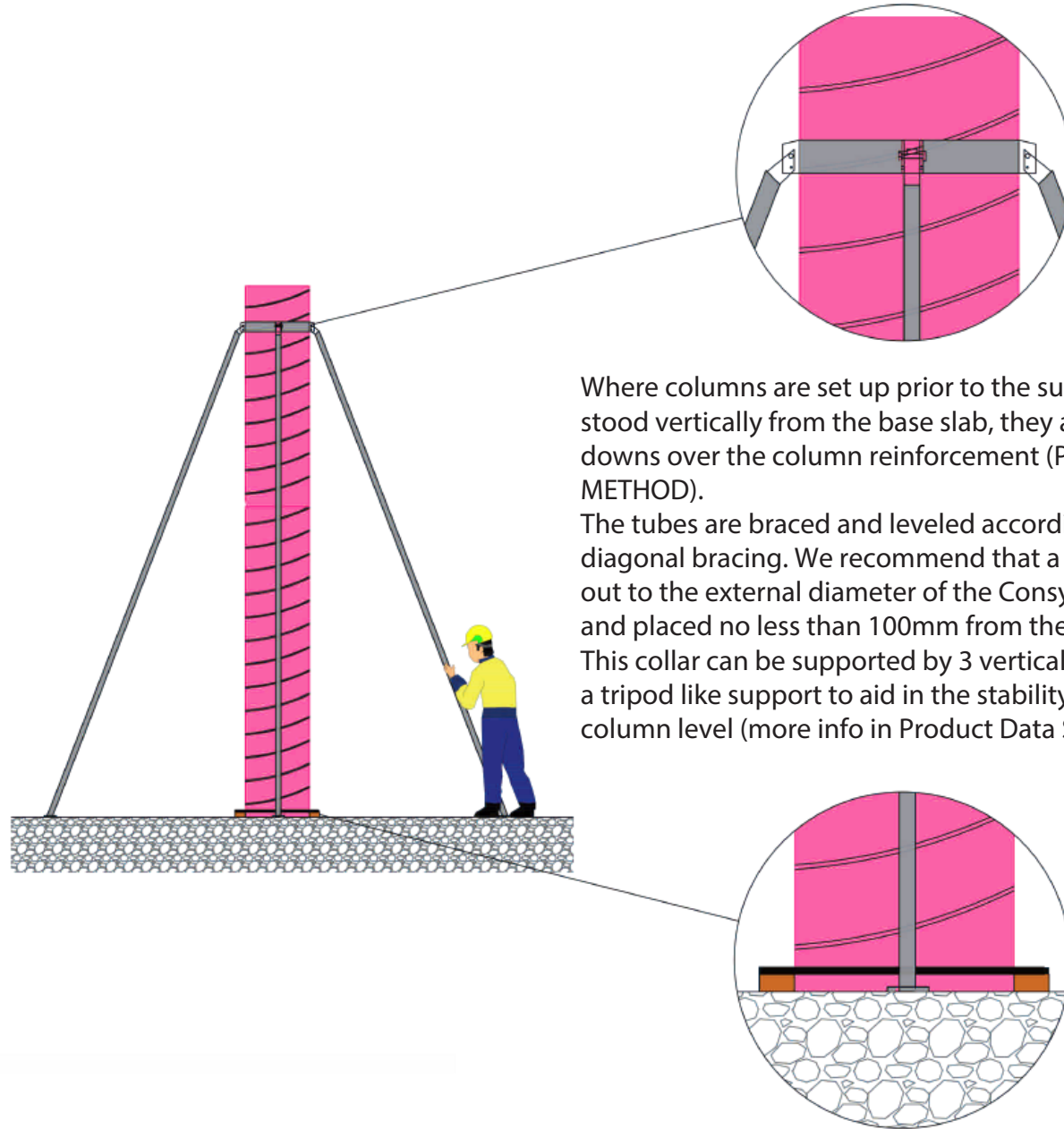

Where columns are set up prior to the suspended slab ie stood vertically from the base slab, they are lowered down over the column reinforcement (POUR UP METHOD).

The tubes are braced and leveled accordingly with diagonal bracing. We recommend that a circular collar cut out to the external diameter of the Consystex tube is used and placed no less than 100mm from the top of the tube. This collar can be supported by 3 vertical bearers to create a tripod like support to aid in the stability of keeping the column level (more info in Product Data Sheet)



CIRCULAR COLUMN FORMWORK

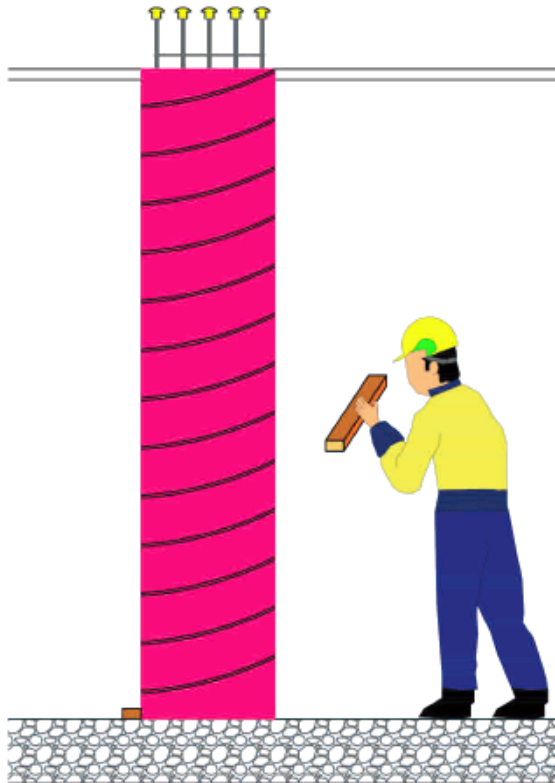

All supports should be removed and the column should be clear of any possible interface.

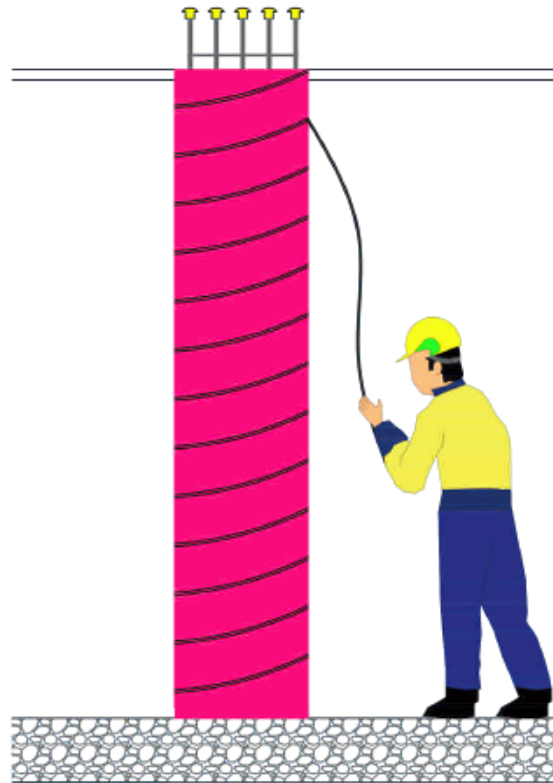

A knife can be used to cut a vertical incision from the top to the bottom of the column. Ensure not to cut through to the concrete as this may scratch or damage the surface finish of the concrete. Alternatively, utilise the option of Stripping Tape, which will split the column vertically for easy removal of the tube.



Once the outer column shell is cut, peel off the tube and safely place on the ground. Cut the column shell into manageable pieces for ease of handling and dispose of responsibly into rubbish bins.